

# A Transmitter for Fox Hunting

*If you want to try fox hunting, someone needs to bring the transmitter.*

Mark Spencer, WA8SME

Fox hunting is introduced to teachers during the ARRL Education and Technology Program (ETP) Teachers Institutes ([www.arrl.org/teachers-institute-on-wireless-technology](http://www.arrl.org/teachers-institute-on-wireless-technology)). This is a very popular activity among the teachers because they see the value of an outdoor activity that uses many aspects of the science and technology of radio. This can reinforce what the students learn about in the classroom. In addition, it relates to the real world of radio direction finding that the students see on many science and nature TV documentaries (see Figure 1).

Our first fox transmitter controller was developed to allow common handheld 2 meter radios to serve as hidden transmitters for ETP classes.<sup>1</sup> This flexible micro-



Figure 1 — Miguel Enriquez, KD7RPP, a Teachers Institute instructor, introducing fox hunting concepts to his students.

<sup>1</sup>Notes appear on page 00.

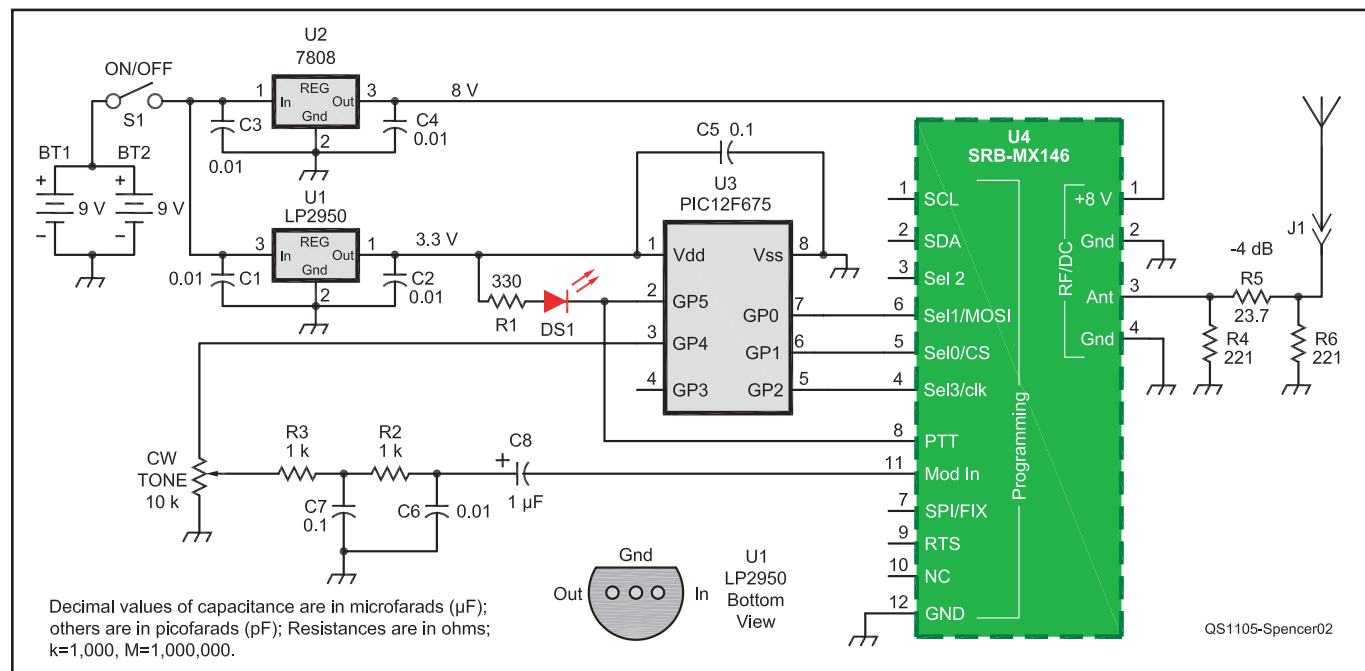

Figure 2 — ETP fox hunter controller circuit diagram and parts list. Digi-Key parts are available from [www.digikey.com](http://www.digikey.com).

BT1, BT2 — 9 V transistor radio type battery.

C1-C4, C6 — 0.01  $\mu\text{F}$  polystyrene or ceramic capacitor.

C5, C7 — 0.1  $\mu\text{F}$  polystyrene or ceramic capacitor.

C7 — 1  $\mu\text{F}$  polystyrene or ceramic capacitor.

DS1 — LED.

J1 — Jack to match desired antenna connection.

R1 — 330  $\Omega$ , 1/4 W, 5% resistor.

R2, R3 — 1 k $\Omega$ , 1/4 W, 5% resistor.

R4, R6 — 221  $\Omega$ , 1/4 W, 1% SMD resistor. (Digi-Key p237fct-nd).

R5 — 23.7  $\Omega$ , 1/4 W, 1% SMD resistor. (Digi-Key p221fct-nd)

S1 — SPST PC board mounting miniature toggle switch.

U1 — 3.3 V regulator IC, LP2950 (Digi-Key lp2950cs-3.3-nd).

U2 — 8 V regulator IC, 7808 (Digi-Key mc7808ct-bpms-nd).

U3 — PIC microprocessor PIC12F675 (Digi-Key PIC12F675-I/P-nd).

U4 — SRB-MX146 2 meter transmit module (see text).

controller-based controller worked well, but because of all the interconnecting plugs and cables, and the variety of handhelds in use, proved to be fairly fragile. Nothing stops a lesson or demonstration faster than an equipment failure. Time is far too valuable.

Our solution to this reliability issue is the simple fox transmitter project presented here. Duplicating this project provides a valuable learning experience covering the use of microcontrollers and also serial communications along with producing a fun, homebrew project. This fox transmitter is made up of a PIC microcontroller and a very frequency agile 2 meter transmitter module. The microcontroller programs the frequency of the transmitter, turns the transmitter on and off at intervals during the fox hunt activity and generates the fox ID as well as the control operator's call sign in Morse code. It is all in an affordable and rugged package.

### Transmitter Module

The 2 meter transmitter module is the SRB Module Transmitter SRB-MX146 available from RPC-Electronics.<sup>2</sup> The module is designed for APRS operation and is a low power (less than 1 W), FM transmitter for sending APRS position packets. The module requires an external antenna, a dc power source, connections to the data audio source and PTT lines. In addition, connections to switches or a microcontroller are needed to set the operating frequency (see Figure 2).

The frequency of the transmitter can be set by three different methods, all detailed in the device documentation. First, four switches can be attached to the module to switch select one of 16 preset APRS channels. Second, the user can hard wire the appropriate pins to a specific channel if frequency agility is not required. This simplifies the interface circuitry for the module. Third, an ASCII stream of data can be sent to the transmitter module via Inter-Integrate Circuit (I2C) or Serial Peripheral Interface (SPI) protocols to set any frequency within the 2 meter band. This data stream is sent to the module by a microcontroller or computer. Frankly, the detail of the documentation that comes with the transmitter module is a bit sparse, particularly with regard to programming the frequency. The following discussion of SPI, along with the module documentation will help you better understand how to program the frequency.

### Serial Peripheral Interface

The SPI protocol is used to send data between devices serially, one bit at a time. In SPI there are slave and master devices. There can be bidirectional communications between the master and the slave(s). For this project, we instead use one way communi-

cations between the master, the microcontroller, and the slave, the transmitter module. It requires up to four interconnecting lines between the master and slave devices to accomplish SPI. The SPI-CS is the device select line. This line is used to signal a connected device that the upcoming data stream is intended for the device. The SPI-MOSI is the data output line from the master to the slave. The SPI-MISO is the data input line from the slave to the master. These two data lines provide the bidirectional communication connections. Finally, the SPI-CLK is the clock line that provides the clock pulses that clock the data bits in and out along the data lines.

The computer or microcontroller that sends data via SPI goes through the following steps.

1. The SPI-CS line is brought to the low state (ground) to signal the slave device that it is about to receive some data.
2. The first bit of the data to be sent is set on the SPI-MOSI line, either high or low (1 or 0). Data can be sent either most significant byte (MSB) or least significant byte (LSB) first, depending on the devices involved.
3. The SPI-CLK line is pulsed high then

low to clock in the bit presented on the SPI-MOSI line to the slave.

4. Steps 2 and 3 are repeated to send the complete byte(s) of data.

5. Finally, the SPI-CS line is brought to the high state (1) to signal the slave that the data transmission is complete and the received data can be accepted.

The oscilloscope snapshot in Figure 3 illustrates the SPI process for sending the first few characters of the data stream to the transmitter module. The scope snapshot was triggered by the SPI-CS line going low. The top trace shows the clock pulses while the bottom trace shows the data bits that are clocked into the transmitter module.

The frequency can be sent to the transmitter module in a number of formats. I will mention only a few here while the module documentation has more detail. The frequency can be sent in binary, hexadecimal or decimal number format, and in Hz, kHz or MHz units. For me, sending the frequency in decimal format in Hz units was more intuitive and gave finer control over the frequency.

What was not clear in the module documentation is that the data that is sent to the transmitter module has to be sent as ASCII characters, not as decimal numbers. ASCII is a number that is sent to computer display devices to represent the character to be displayed. For instance, if you want to display the decimal number 1, you need to send a value that represents the character "1"... you would send the ASCII number that represents the character "1," not the actual number 1. The ASCII number that represents the character "1" is 49. If you send the decimal number 1 to a computer display device, you probably would see nothing happen at best, or some unexpected garbage because the decimal number 1 is a control code for START OF HEADING. A subset of the ASCII number set for the relevant data that is sent to the transmitter module to set

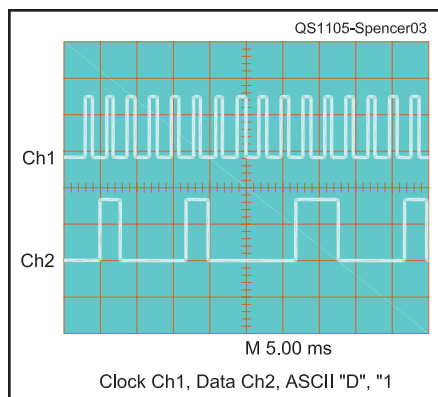

Figure 3 — SPI data stream.

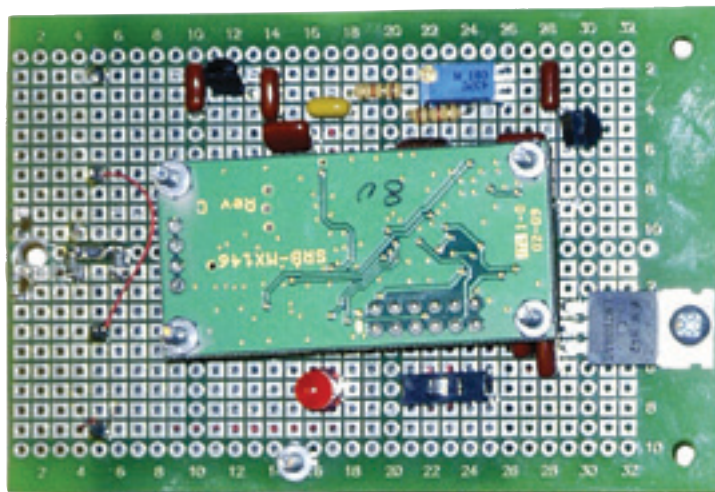

Figure 4 — ETP fox prototype.

**Table 1**

**Decimal Digit to ASCII Conversion**

Decimal Digit or Letter	ASCII Coded Digit
0	48
1	49
2	50
3	51
4	52
5	53
6	54
7	55
8	56
9	57
D	68

the frequency is listed in Table 1.

For example, to set the transmitter module to the frequency of 146.52 MHz, the ASCII data stream D146520000 would be sent over the SPI-MOSI line to the module with the MSB sent first in each byte. In other words, the ASCII number sequence to accomplish this frequency setting would be: 49, 68, 52, 54, 53, 50, 48, 48, 48, 48.

Once the frequency is set, it is a simple matter of bringing the PTT line of the transmitter module low and applying an audio signal to the audio input line to begin transmitting. There is one precautionary quirk of the module. The voltages applied to the input lines of the module must be at CMOS levels (3.3 V maximum). Therefore the controlling interface voltages must be adjusted accordingly.

**The Microcontroller**

The fox transmitter project uses the PIC12F675 microcontroller. This powerful little device is programmed to set the frequency of the transmitter module and then begin the fox transmission cycle of one minute on; sending the fox ID in Morse code, the control operators call sign at the end of the one minute transmission period, then shut down for four minutes before the cycle is repeated. The frequency, fox ID (MOE, MOI, MOS, MOH, MO5) and the control operator's call sign are programmed into the microcontroller's firmware (which can be changed with re-programming).

The microcontroller software that was developed by the author is simply modified by changing the frequency and call sign variables in the program to the specific data needed by the builder. The software is available on the QST-in-Depth website.<sup>3</sup>

It all comes together in the circuit depicted in Figure 2. The fox transmitter is powered by two 9 V batteries wired in parallel (a modification of this arrangement will be mentioned in a moment). The 9 V from the batteries is connected to the high current 5 V regulator

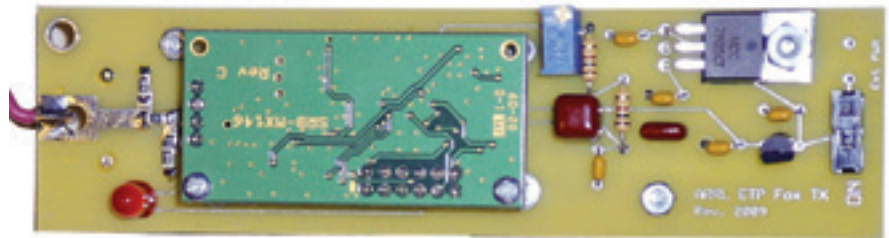

Figure 5 — ETP fox final project.

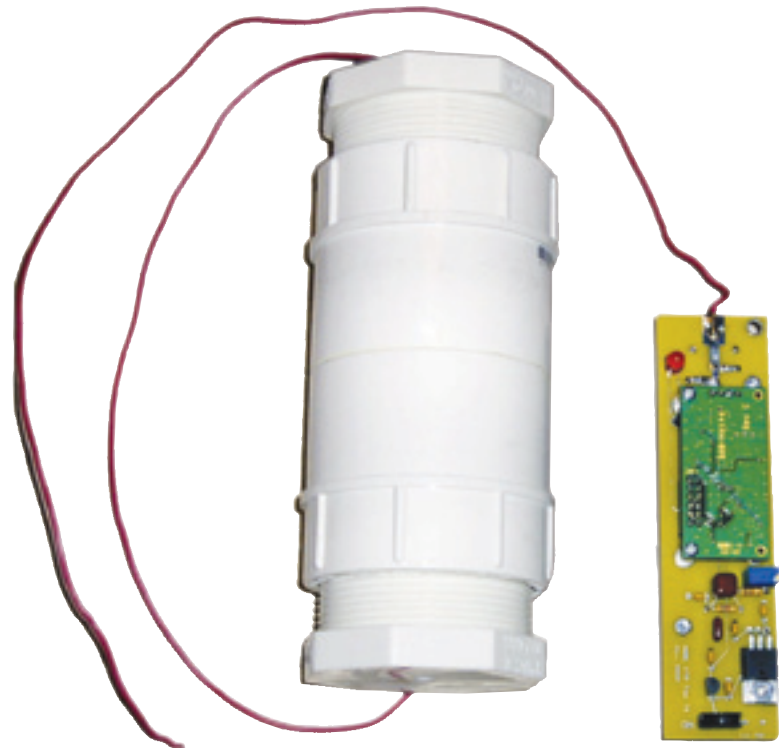

Figure 6 — ETP fox ready for action in a PVC protective housing.

**Hamspeak**

- **APRS** — Automatic position reporting system. System that accepts global positioning system (GPS) position data from a GPS satellite receiver and processor, formats it into an AX-25 packet for transmission via Amateur Radio, usually on 144.39 MHz. Position data is available via radio or over the Internet.
- **ASCII** — American Standard Code for Information Interchange. A computer “alphabet” obtained by mapping each printable and control character into a seven bit data word (often implemented with eight bits by including an error checking parity bit). See [www.cs.tut.fi/~jkorpela/chars.html](http://www.cs.tut.fi/~jkorpela/chars.html).
- **CMOS** — Complementary metal oxide semiconductor. An integrated circuit logic family with particularly low power requirements.
- **Fox hunt** — Competitive Amateur Radio activity in which hams track down a transmitted signal. Usually directive antennas and triangulation are used.
- **Oscilloscope** — Type of electronic test instrument traditionally with a cathode ray display screen that shows time on the horizontal axis and voltage on the vertical axis.
- **PIC microcontroller** — Programmable interface controller. One of a family of processor based integrated circuits that can be programmed to perform multiple functions.
- **PTT** — Push-to-talk, a method of transmit-receive switching in which a button or lever on the microphone is used to actuate the circuitry used to switch from receive to transmit mode.

that provides power to the transmitter module. The transmitter module is available in two forms, a high power (500 mW and 8 V) and a low power (350 mW and 5 V) module. I chose the low power module for the fox and therefore the voltage regulator is a 7805. If you choose the high power module, the 9 V batteries should be wired in series and the voltage regulator should be a 7808. The second 3.3 V regulator provides power to the PIC12F675.

I mentioned that the transmitter module requires CMOS level voltages on the control and data lines. I chose to power the PIC12F675 with 3.3 V to simplify the interfacing with the transmitter module. Normally the PIC12F675 is powered at 5 V, but is rated to operate between 2 and 5.5 V, so it handles 3.3 V just fine (and this certainly uncompliments the interconnecting circuitry).

The audio frequency generated by the PIC12F675 to produce the Morse code is in the form of a square wave. The resistor and capacitor components between the microcontroller output line and the transmitter audio input line provides some filtering and microphone gain control to clean up the square wave.

Finally, I use the fox transmitters to demonstrate the concepts of fox hunting to teachers often times in very close and

confined spaces. This requires the use of some low power transmitters and 350 mW is some significant power close in. Therefore, approximately 4 dB of attenuation was added to the circuit to cut the power down a bit. More or less attenuation can be added if needed for your particular application.

The hand wired prototype of the fox transmitter is shown in Figure 4. Formal circuit boards were designed for the final fox transmitters to make them more uniform and rugged as shown in Figure 5. The narrow board design allows for the foxes to be housed in PVC pipe fittings to make them more rugged and water resistant (see Figure 6).

### In Summary

Fox hunting is a great, and useful, activity for Scout groups, schools and ham groups. It combines outdoor activities with some science of radio and radio operating techniques in a refreshing way that just might stimulate further interest in ham radio — and just might help save someone's life. This fox transmitter project might be a good one for a club homebrew project that supports not only club activities but also could support your local school or Scout organizations, and give you an opportunity to introduce ham radio in a very positive way.

### Notes

<sup>1</sup>See [www.arrrl.org/etp-kits-projects](http://www.arrrl.org/etp-kits-projects), click on SCHOOL FOX HUNTING ACTIVITY, then LEARN MORE.

<sup>2</sup>[www.rpc-electronics.com/rf.php](http://www.rpc-electronics.com/rf.php)

<sup>3</sup>[www.arrrl.org/qst-in-depth](http://www.arrrl.org/qst-in-depth)

*ARRL member and Amateur Extra class operator Mark Spencer, WA8SME, was the ARRL Education and Technology Program (ETP) Coordinator when this article was written. He recently transitioned to an engineering position with a firm that does rapid research and development of prototype unmanned underwater and other autonomous maritime vehicles for the Office of Naval Research and other Department of Defense agencies. He still maintains close ties to the ETP and provides as much support as time permits. So if you need some help or have some questions about this project, please be patient. One side point of interest; Mark states that he has used every content area presented during the ARRL Teachers Institute and the skills he learned in his over 45 years as a ham radio operator in his position as a Research and Development engineer. Quite a validation of the ETP — and ham radio! Mark can be reached at [wa8sme@comcast.net](mailto:wa8sme@comcast.net).*



## New Products

### AIM UHF ANTENNA ANALYZER FROM ARRAY SOLUTIONS

◇ The AIM UHF antenna analyzer from Array Solutions is similar to the AIM 4170C but with extended frequency coverage. The new unit operates from 5 kHz to 1 GHz and features a temperature compensated oscillator (TCXO), scan averaging up to 256 times and an expansion port for accessories. The package includes a wall power supply, calibration loads, a USB cable, free software updates and a printed *Quick Start* guide. Price: \$895.



For more information, visit [www.array-solutions.com](http://www.array-solutions.com).

### LOOPS-N-MORE VHF ANTENNAS

◇ Loops-N-More offers halo type half-wave loop antennas for the 6, 2 and 1.25 meter amateur bands. Based on the proven KB6KQ designs, the antennas are made from 6061 aluminum with stainless steel hardware. Rated at up to 750 W, these antennas are horizontally polarized and designed for SSB/CW operation from mobile or home stations. Price: 6 meter loop, \$135. 2 meter or 1.25 meter loop, \$65. For more information, visit [loopsnmore.com](http://loopsnmore.com).

### ICOM IC-7410 HF/6 METER TRANSCEIVER

◇ ICOM's new IC-7410 replaces the IC-746PRO. The '7410 uses faster digital signal processing and technology developed from the current IC-7600/7700/7800 series of transceivers. Optional 3 kHz and 6 kHz roofing filters are available. The IC-7410 comes with a standard type B USB connector on its back panel. Modulation input, audio output, RTTY demodulator output and CI-V command can be controlled via the USB cable. Also, a conventional CI-V remote control jack is built into the IC-7410. Optional RS-BA-1 remote control software has been announced with details to come. Price class: \$2000. For more information, visit your local dealer or [www.icomamerica.com](http://www.icomamerica.com).

